

Candidate Name	Centre Number	Candidate Number



## GCE AS/A level

1321/01

**New AS**

### PHYSICS

### PH1: MOTION ENERGY AND CHARGE

P.M. TUESDAY, 13 January 2009

1¼ hours

#### ADDITIONAL MATERIALS

In addition to this examination paper, you will require a calculator and a **Data Booklet**.

#### INSTRUCTIONS TO CANDIDATES

Write your name, centre number and candidate number in the spaces at the top of this page.

Answer **all** questions.

Write your answers in the spaces provided in this booklet.

#### INFORMATION FOR CANDIDATES

The total number of marks available for this paper is 80.

The number of marks is given in brackets at the end of each question or part question.

You are reminded of the necessity for good English and orderly presentation in your answers.

You are reminded to show all working. Credit is given for correct working even when the final answer given is incorrect.

For Examiner's use only		
Question	Maximum Mark	Mark Awarded
<b>1.</b>	<b>7</b>	
<b>2.</b>	<b>7</b>	
<b>3.</b>	<b>12</b>	
<b>4.</b>	<b>8</b>	
<b>5.</b>	<b>9</b>	
<b>6.</b>	<b>12</b>	
<b>7.</b>	<b>7</b>	
<b>8.</b>	<b>18</b>	
<b>Total</b>	<b>80</b>	

1. (a) Newton's second law of motion can be expressed by the equation

$$\Sigma F = ma$$

Identify and name the vector quantities in this equation. [2]

.....

.....

.....

(b) A car is stuck in sand. Two ropes are attached securely to the car's bumper as shown. One rope is pulled with a force of 600 N due west. The other is pulled with a force of 450 N due south.

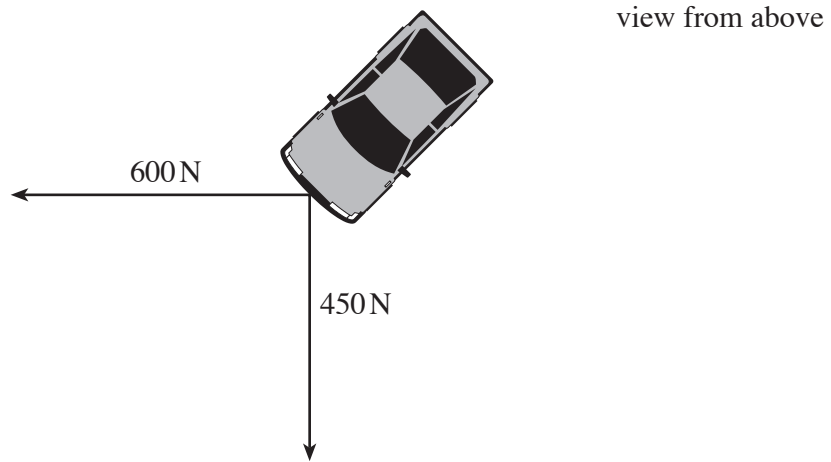

(i) Calculate the magnitude and direction of the resultant of these two forces. [3]

.....

.....

.....

.....

.....

(ii) The car remains stationary but the bumper suddenly breaks away. Calculate the initial acceleration of the bumper if its mass is 5.0 kg. [2]

.....

.....

.....

2. A polythene rod is rubbed with a duster. The rod is then scraped across the metal cap of a digital coulombmeter as shown in the diagram (a coulombmeter is a device for measuring electrical charge).

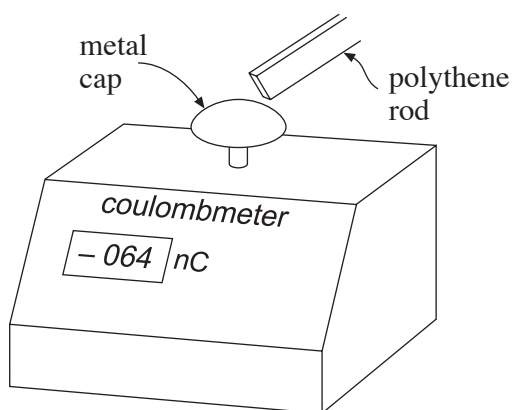

- (a) (i) Explain why the reading on the coulombmeter is negative. [1]

.....

.....

.....

.....

- (ii) State the sign of the charge acquired by the duster. Explain your reasoning. [2]

.....

.....

.....

- (b) The coulombmeter is now discharged by connecting a wire from the metal cap to the ground. The coulombmeter reading falls to zero.

- (i) Calculate the number of charged particles that flow from the coulombmeter. [2]

.....

.....

.....

- (ii) Calculate the time taken for this number of charged particles to flow past a point in the wire if the mean discharge current is  $2\ \mu\text{A}$ . [2]

.....

.....

.....

3. (a) State Ohm's law.

[2]

.....

.....

(b) In the circuit below the voltmeter reads 9 V and the resistance of the bulbs are as shown.

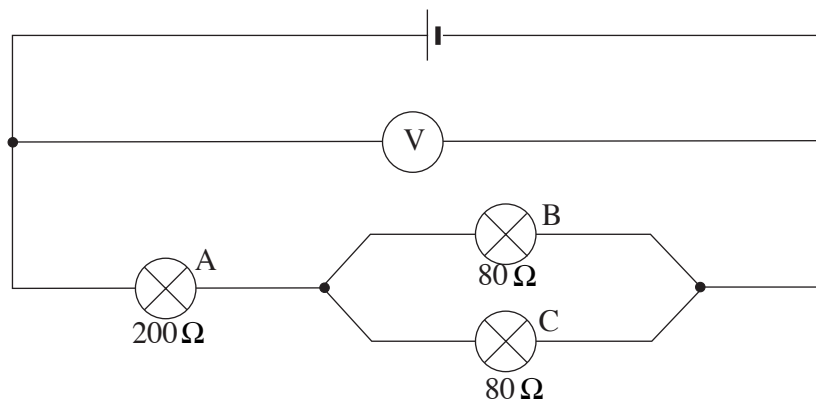

(i) Calculate the effective resistance of the bulb combination.

[3]

.....

.....

.....

(ii) Calculate the current through

(I) bulb A;

[2]

.....

.....

(II) bulb C.

[1]

.....

(iii) Calculate the ratio of the power dissipated in bulbs A and C and compare the brightness of the bulbs.

[4]

.....

.....

.....

.....

.....

.....

4. A graph of current against potential difference (p.d.) is given for a piece of metal wire.

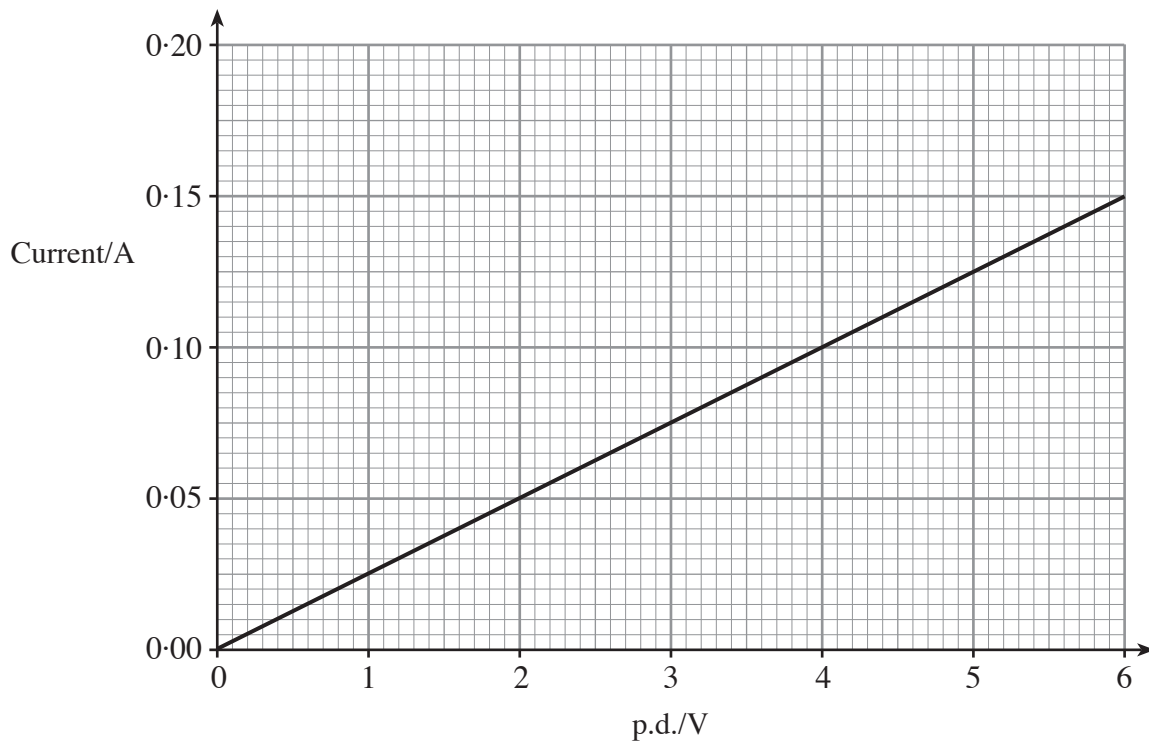

- (a) Calculate the resistance of the wire.

[1]

.....

.....

- (b) What does the graph tell us about the temperature of the wire as the p.d. across it is increased? Explain your answer.

[2]

.....

.....

.....

- (c) The wire has a length of 2.5 m and a **diameter** of  $2.0 \times 10^{-4}$  m. Calculate the resistivity of the metal.

[3]

.....

.....

.....

.....

- (d) Draw on the same graph-grid the current against p.d. graph for a wire, made of the same metal and of the same diameter ( $2.0 \times 10^{-4}$  m) but of length 7.5 m.

[2]

5. A ball of mass  $0.60\text{ kg}$  is dropped from the top of a building  $80\text{ m}$  high.

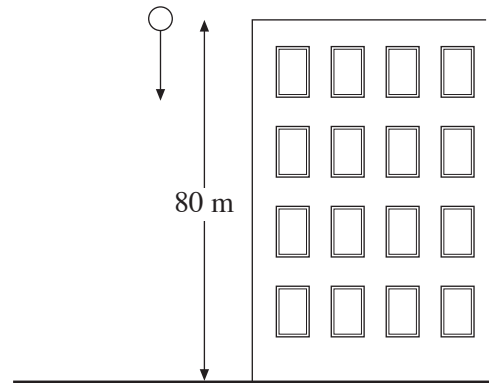

- (a) Calculate the initial gravitational potential energy of the ball. [2]

.....

.....

.....

- (b) The ball reaches the ground with a velocity of  $30\text{ ms}^{-1}$ . Calculate its kinetic energy. [2]

.....

.....

.....

- (c) (i) Calculate the fraction of the initial gravitational potential energy that is **not** converted into kinetic energy of the ball during the fall. [1]

.....

.....

- (ii) Explain, referring to molecules, what has happened to this 'missing' energy. [2]

.....

.....

.....

- (d) Calculate the mean resistive force acting on the ball during its fall. [2]

.....

.....

.....

**BLANK PAGE**

6. An equation which can be applied to a circuit containing a cell of e.m.f.  $E$  and internal resistance  $r$  is

$$V = E - Ir$$

- (a) Explain carefully, **in terms of energy**, the meanings of  $V$ ,  $E$  and  $Ir$ . [4]

.....

.....

.....

.....

.....

.....

.....

.....

.....

.....

- (b) Four cells, each of e.m.f.  $1.5\text{ V}$  and internal resistance  $0.2\ \Omega$ , are connected in series to make a battery of e.m.f.  $6.0\text{ V}$ . A  $4.0\ \Omega$  resistor is connected across the battery.

- (i) Draw a circuit diagram of this arrangement which includes the internal resistance of the battery. [1]

- (ii) Calculate the current. [2]

.....

.....

.....

- (iii) Calculate the p.d. across the  $4.0\ \Omega$  resistor. [1]

.....

.....



(c) After the resistor has been left connected for some time, one of the cells starts to show signs of running down. Its e.m.f. has dropped to 1.20 V and its internal resistance has risen to 0.40  $\Omega$ .

Investigate whether or not, in order to maximise the current through the 4.0  $\Omega$  resistor, it would be better to remove the run down cell, leaving the other three in series. [4]

.....

.....

.....

.....

.....

.....

.....

.....

7. Undersea turbines are being developed as a cost-effective means of generating power from tidal streams. Many suitable sites for the location of these turbines have been identified around our coastline. The diagram shows a single turbine of **diameter** 16 m.

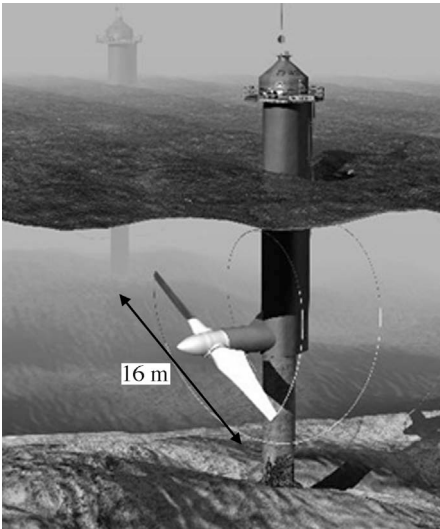

- (a) The density of sea water is  $1050 \text{ kg m}^{-3}$ . Explain what this statement means. [1]

.....

.....

.....

- (b) The following equation gives the power input to the turbine

$$P = \frac{1}{2} \rho A v^3$$

where  $\rho$  = density,  $A$  = Area swept out by turbine blades,  $v$  = velocity of sea water.

- (i) Calculate the input power if the turbine is in a tidal stream of velocity  $2.5 \text{ ms}^{-1}$ . [2]

.....

.....

.....

- (ii) The manufacturers say that they would expect a turbine like this to produce an output of 1000 kW of power when in actual use in a tidal stream of  $2.5 \text{ ms}^{-1}$ . Use this information and your answer to (b)(i) to calculate the percentage efficiency of the turbine. [1]

.....

.....

.....

- (iii) Explain in terms of the kinetic energy of the water why the turbine is not 100% efficient. [1]

.....

(iv) Supporters of tidal stream power claim that ‘a single tidal turbine would produce the same electrical power as several wind turbines of the same diameter’.

(I) Explain, using the equation on the previous page, why this statement should be true. (Assume that the wind velocity is similar to that of a tidal stream.) [1]

.....  
.....

(II) Suggest **one** advantage of choosing the tidal stream option. [1]

.....  
.....  
.....  
.....

8. The velocity-time graph shown represents the first 70 seconds of the motion of a car moving along a straight level road.

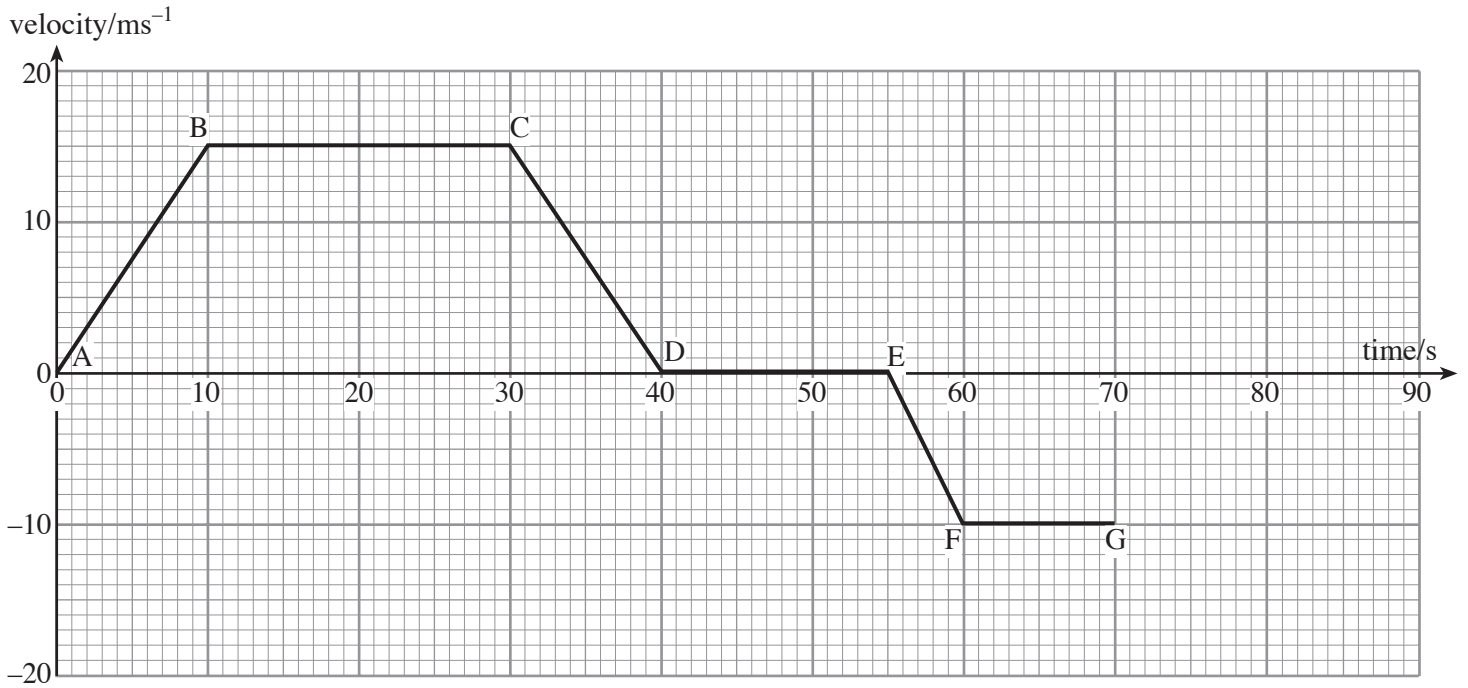

An air freshener hangs freely from a thread inside the car. During the first 10 seconds of the car's motion (A to B on the graph) the thread is inclined to the vertical as shown below.

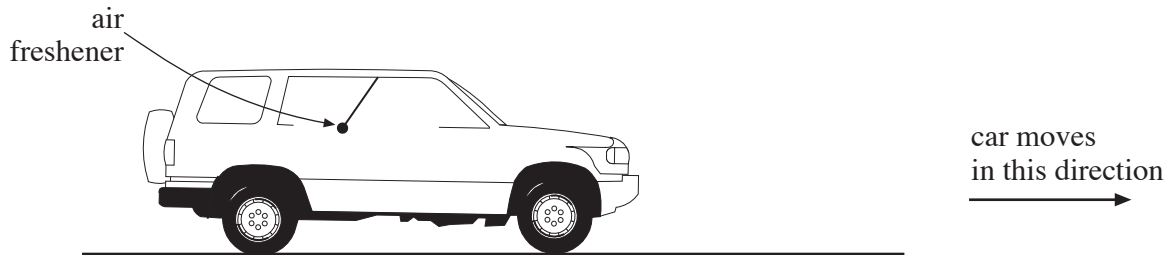

- (a) (i) Describe the motion of the car from A to B. [1]

.....

- (ii) Sketch, on the diagrams below, how the thread is inclined (if at all), when the car is moving between the points indicated beneath each picture. [3]

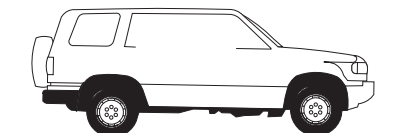

B to C

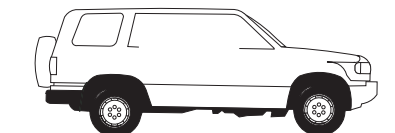

C to D

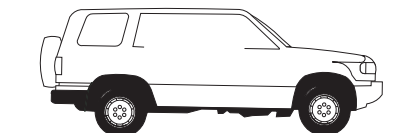

E to F

- (iii) Write down another period during the car's motion where the inclination of the thread would be the same as it was between B and C. [1]

.....

- (iv) Explain your answer to (iii) in terms of the forces acting on the air freshener. [1]

.....

.....

- (b) At 70 seconds from the start the car starts to slow down at a uniform rate. During the deceleration the car travels a further 75 m before coming to rest. Calculate the time taken for the car to come to rest and complete the velocity-time graph to show this final stage. [3]

.....

.....

.....

- (c) (i) Calculate the car's displacement between

- (I) 0 and 10 seconds; [2]

.....

.....

.....

- (II) 0 and 30 seconds; [1]

.....

.....

- (III) 0 and 40 seconds. [1]

.....

.....

- (ii) Hence, sketch a displacement-time graph **for the first 50 seconds** of the motion on the grid **on page 14**. Start by providing a scale on the vertical axis and plotting the points obtained from (c)(i).

**THE GRAPH GRID IS ON PAGE 14**

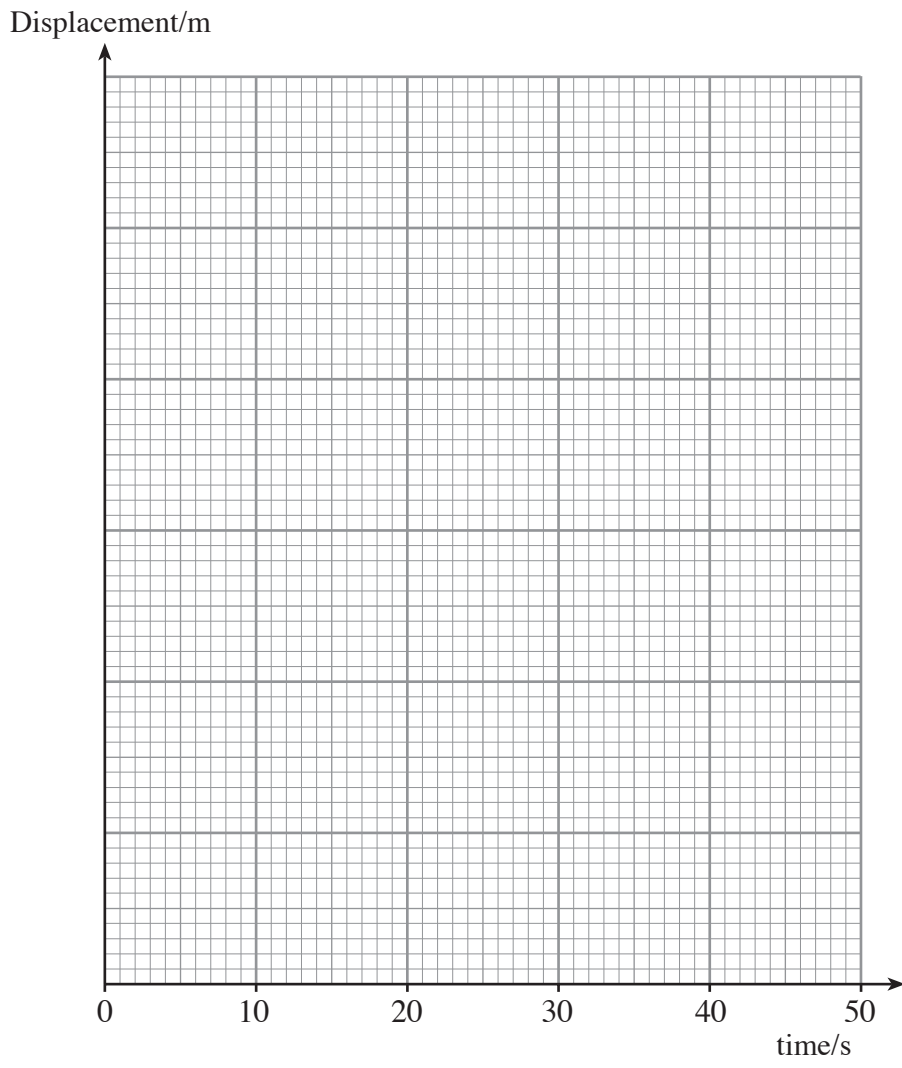

[5]



A series of horizontal dotted lines for writing, spanning the width of the page.