

Paper Reference(s)

**6678**

# **Edexcel GCE**

## **Mechanics M2**

**Advanced/Advanced Subsidiary**  
**Tuesday 18 June 2002 – Afternoon**  
**Time: 1 hour 30 minutes**

**Materials required for examination**

Answer Book (AB16)  
Mathematical Formulae (Lilac)  
Graph Paper (ASG2)

**Items included with question papers**

Nil

**Candidates may use any calculator EXCEPT those with the facility for symbolic algebra, differentiation and/or integration. Thus candidates may NOT use calculators such as the Texas Instruments TI 89, TI 92, Casio CFX 9970G, Hewlett Packard HP 48G**

### **Instructions to Candidates**

---

In the boxes on the answer book, write the name of the examining body (Edexcel), your centre number, candidate number, the unit title (Mechanics M2), the paper reference (6678), your surname, other name and signature.

Whenever a numerical value of  $g$  is required, take  $g = 9.8 \text{ m s}^{-2}$ .

When a calculator is used, the answer should be given to an appropriate degree of accuracy.

### **Information for Candidates**

---

A booklet 'Mathematical Formulae and Statistical Tables' is provided.

Full marks may be obtained for answers to ALL questions.

This paper has seven questions. Pages 7 and 8 are blank.

### **Advice to Candidates**

---

You must ensure that your answers to parts of questions are clearly labelled.

You must show sufficient working to make your methods clear to the Examiner. Answers without working may gain no credit.

1. The velocity  $\mathbf{v}$  m s<sup>-1</sup> of a particle  $P$  at time  $t$  seconds is given by

$$\mathbf{v} = (3t - 2)\mathbf{i} - 5t\mathbf{j}.$$

- (a) Show that the acceleration of  $P$  is constant.

(2)

At  $t = 0$ , the position vector of  $P$  relative to a fixed origin  $O$  is  $3\mathbf{i}$  m.

- (b) Find the distance of  $P$  from  $O$  when  $t = 2$ .

(6)

---

2. A particle  $P$  moves in a straight line so that, at time  $t$  seconds, its acceleration  $a$  m s<sup>-2</sup> is given by

$$a = \begin{cases} 4t - t^2, & 0 \leq t \leq 3, \\ \frac{27}{t^2}, & t > 3. \end{cases}$$

At  $t = 0$ ,  $P$  is at rest. Find the speed of  $P$  when

- (a)  $t = 3$ ,

(3)

- (b)  $t = 6$ .

(5)

---

3.

Figure 1

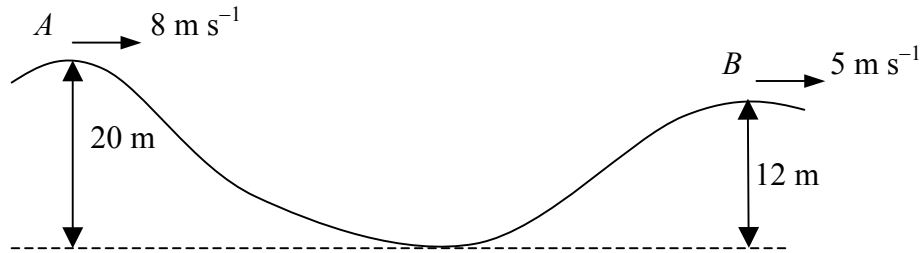

Figure 1 shows the path taken by a cyclist in travelling on a section of a road. When the cyclist comes to the point  $A$  on the top of a hill, she is travelling at  $8 \text{ m s}^{-1}$ . She descends a vertical distance of  $20 \text{ m}$  to the bottom of the hill. The road then rises to the point  $B$  through a vertical distance of  $12 \text{ m}$ . When she reaches  $B$ , her speed is  $5 \text{ m s}^{-1}$ . The total mass of the cyclist and the cycle is  $80 \text{ kg}$  and the total distance along the road from  $A$  to  $B$  is  $500 \text{ m}$ . By modelling the resistance to the motion of the cyclist as of constant magnitude  $20 \text{ N}$ ,

(a) find the work done by the cyclist in moving from  $A$  to  $B$ . (5)

At  $B$  the road is horizontal. Given that at  $B$  the cyclist is accelerating at  $0.5 \text{ m s}^{-2}$ ,

(b) find the power generated by the cyclist at  $B$ . (4)

---

4.

Figure 1

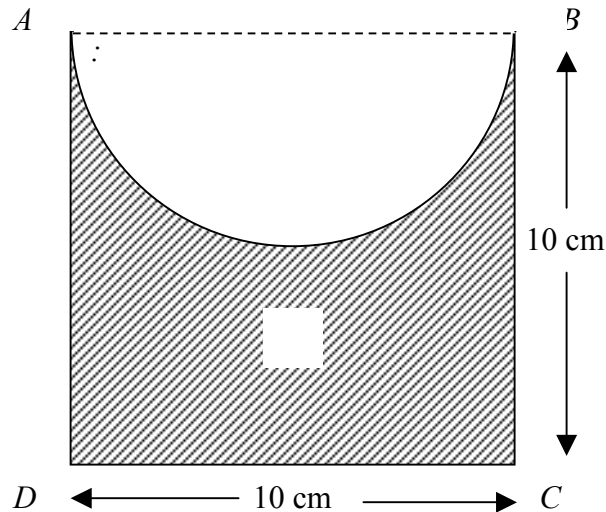

A uniform lamina  $L$  is formed by taking a uniform square sheet of material  $ABCD$ , of side 10 cm, and removing the semi-circle with diameter  $AB$  from the square, as shown in Fig. 2.

(a) Find, in cm to 2 decimal places, the distance of the centre of mass of the lamina  $L$  from the mid-point of  $AB$ .

(7)

[The centre of mass of a uniform semi-circular lamina, radius  $a$ , is at a distance  $\frac{4a}{3\pi}$  from the centre of the bounding diameter.]

The lamina is freely suspended from  $D$  and hangs at rest.

(b) Find, in degrees to one decimal place, the angle between  $CD$  and the vertical.

(4)

5. A particle is projected from a point with speed  $u$  at an angle of elevation  $\alpha$  above the horizontal and moves freely under gravity. When it has moved a horizontal distance  $x$ , its height above the point of projection is  $y$ .

(a) Show that

$$y = x \tan \alpha - \frac{gx^2}{2u^2} (1 + \tan^2 \alpha). \quad (5)$$

A shot-putter puts a shot from a point  $A$  at a height of 2 m above horizontal ground. The shot is projected at an angle of elevation of  $45^\circ$  with a speed of  $14 \text{ m s}^{-1}$ . By modelling the shot as a particle moving freely under gravity,

(b) find, to 3 significant figures, the horizontal distance of the shot from  $A$  when the shot hits the ground, (5)

(c) find, to 2 significant figures, the time taken by the shot in moving from  $A$  to reach the ground. (2)

---

6. A small smooth ball  $A$  of mass  $m$  is moving on a horizontal table with speed  $u$  when it collides directly with another small smooth ball  $B$  of mass  $3m$  which is at rest on the table. The balls have the same radius and the coefficient of restitution between the balls is  $e$ . The direction of motion of  $A$  is reversed as a result of the collision.

(a) Find, in terms of  $e$  and  $u$ , the speeds of  $A$  and  $B$  immediately after the collision. (7)

In the subsequent motion  $B$  strikes a vertical wall, which is perpendicular to the direction of motion of  $B$ , and rebounds. The coefficient of restitution between  $B$  and the wall is  $\frac{3}{4}$ .

Given that there is a second collision between  $A$  and  $B$ ,

(b) find the range of values of  $e$  for which the motion described is possible. (6)

---

7.

Figure 3

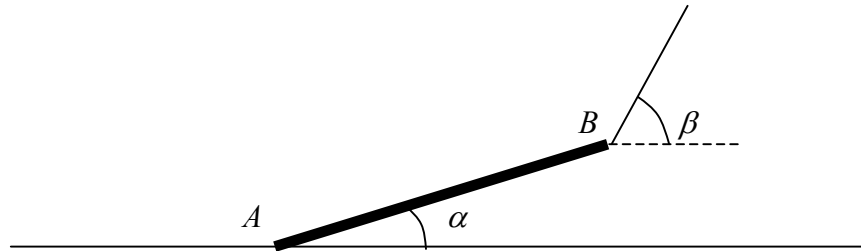

A straight log  $AB$  has weight  $W$  and length  $2a$ . A cable is attached to one end  $B$  of the log. The cable lifts the end  $B$  off the ground. The end  $A$  remains in contact with the ground, which is rough and horizontal. The log is in limiting equilibrium. The log makes an angle  $\alpha$  to the horizontal, where  $\tan \alpha = \frac{5}{12}$ . The cable makes an angle  $\beta$  to the horizontal, as shown in Fig. 3. The coefficient of friction between the log and the ground is 0.6. The log is modelled as a uniform rod and the cable as light.

(a) Show that the normal reaction on the log at  $A$  is  $\frac{2}{5}W$ . (6)

(b) Find the value of  $\beta$ . (6)

The tension in the cable is  $kW$ .

(c) Find the value of  $k$ . (2)

---

**END**